

# NanoSpinner

PilotLine-PE300



HYBRID ELECTROSPINNING TECHNOLOGY



## About **INOVENSO**

We started our academic activities in 2007 working on nanotechnologies under the Nano Fiber Membrane Group (NanoFMG). After focusing on improving Nanofiber quality during Electrospinning process, we established our born global company Inovenso in 2010. Our name is acronym of Innovative Engineering Solutions. We aimed to developed very efficient electrospinning machines and accelerate nanofiber science. We quickly become a bridge company between academia and industry and proudly contributed to hundreds of scientific projects using polymer nanofibers for wide variety of applications such as biomedical tissue,engineering, pharmaceutical, energy, filtration, material sciences, textile, agriculture, cosmetics.

We brought new innovative approaches to overcome many common obstacles in the nanofiber production field such as scalability, flexibility, standardization and reproducibility with develops customized electrospinning devices all the way from any lab scale desktop starter kits to industrial scale electrospinning machines. It was only possible with working very closely with our clients, understanding their real needs and sharing their concerns and problems.

For more info visit: [www.inovenso.com](http://www.inovenso.com)

## About **PE-300**

The **PE-300** is our cutting-edge electrospinning device for the continuous production of nanofibers. Its major advantage is scalability, as it's suitable for both big-scale production line as well as small-scale R&D projects. The NS Pilot Line enables high productivity for mass production of nanofibers with high-functioning 18 nozzles, in addition to energy saving mode of single nozzle function for small-scale R&D projects.

Its unique design differentiates **PE-300** from other devices with more flexible scalability for production of nanofibers and composites. Its ability to accommodate 2 syringe pumps and 2 high voltage power suppliers enables independently controlled simultaneous runs with up to 2 different polymers.

## NanoSpinner PilotLine-PE300

Hybrid Electrospinning Technology

**PE-300** uses a patented, unique  
“Hybrid Electrospinning Technology”.

This new technique combines the advantages of both needle-based and needle-less electrospinning, as follows: High throughput productivity, with an accurate control over the process and the final product.  
(from needle-based Electrospinning).



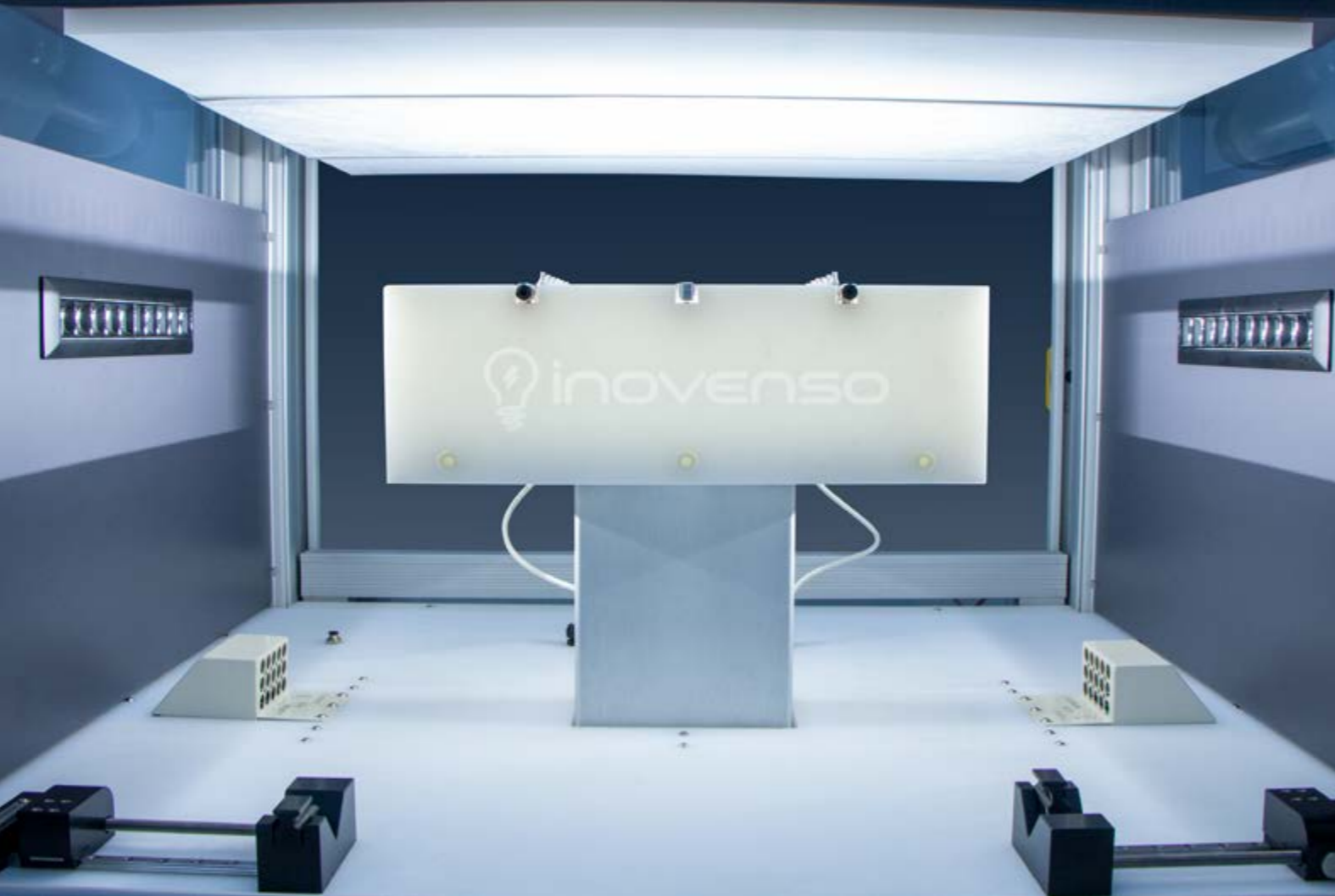

## UNIQUE USER INTERFACE

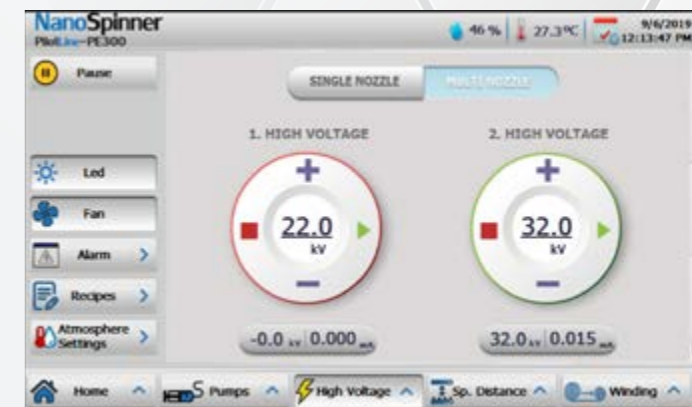

### USER FRIENDLY

Specially designed control panel with user-friendly interface makes operations much easier.

### ACCURATE CONTROL

Operator will have the full control of all parameters.

### RECIPE RECALL

The recipes recall function enables users to save parameters and recall instantly.

# PRODUCT DESCRIPTION

**NanoSpinner**  
PilotLine-PE300

NanoSpinner  
PILOTLINE

## • Single and Multi Nozzle Operation

Up to 18 Nozzles during full operation

Possible option of eco mode with single nozzle

Nozzles with wide variety of diameters could be used simultaneously

2 Precise syringe pumps

2 High voltage power suppliers (40kV). Each of them charges different pipe sets.

## • Roll to Roll Collector:

Fiber Deposition Width: 300 mm

Substrate Winding Speed: 0,01 m/min - 10 m/min

Coating Homogeneity System: X-axis repetitive motion

Stroke of Coating Homogeneity System: 10mm - 80mm

Speed of Coating Homogeneity System: 5-50 mm/sec

## • Minimum Required Solution

Single Nozzle Feeding: 2ml

Feeding each Pipe Set: 15ml

Full Loading: 60ml

## • Advanced Automation System

Full control of process and system via 9 inches touch screen panel saving all important parameters and recall them when needed. Equipped with extra safety features such as spark protection, safety-door option, integrated safety-relays.

## • High Precision Micro Pump

Number of Pumps: 2 units

Flow Rate: 0.35 - 7123 ml/h (BD 60 ml syringe)

Flow Rate Precision: 0.01 ml

Available Syringes: All types are available

Available Pump Systems: Syringe / Peristaltic (Optional)



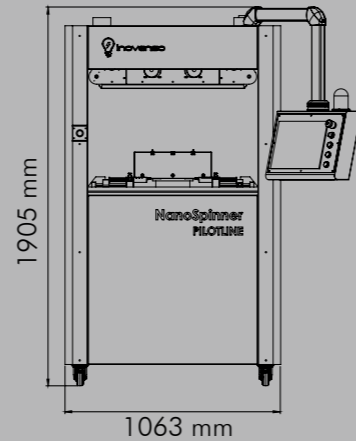
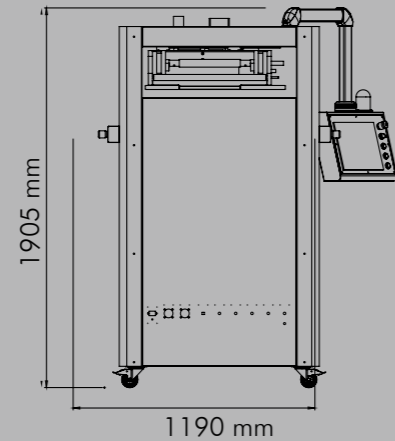
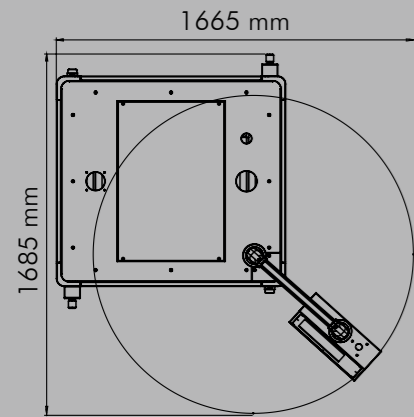

Weight: Approx 400 kg/881 lbs

## TECHNICAL DRAWING

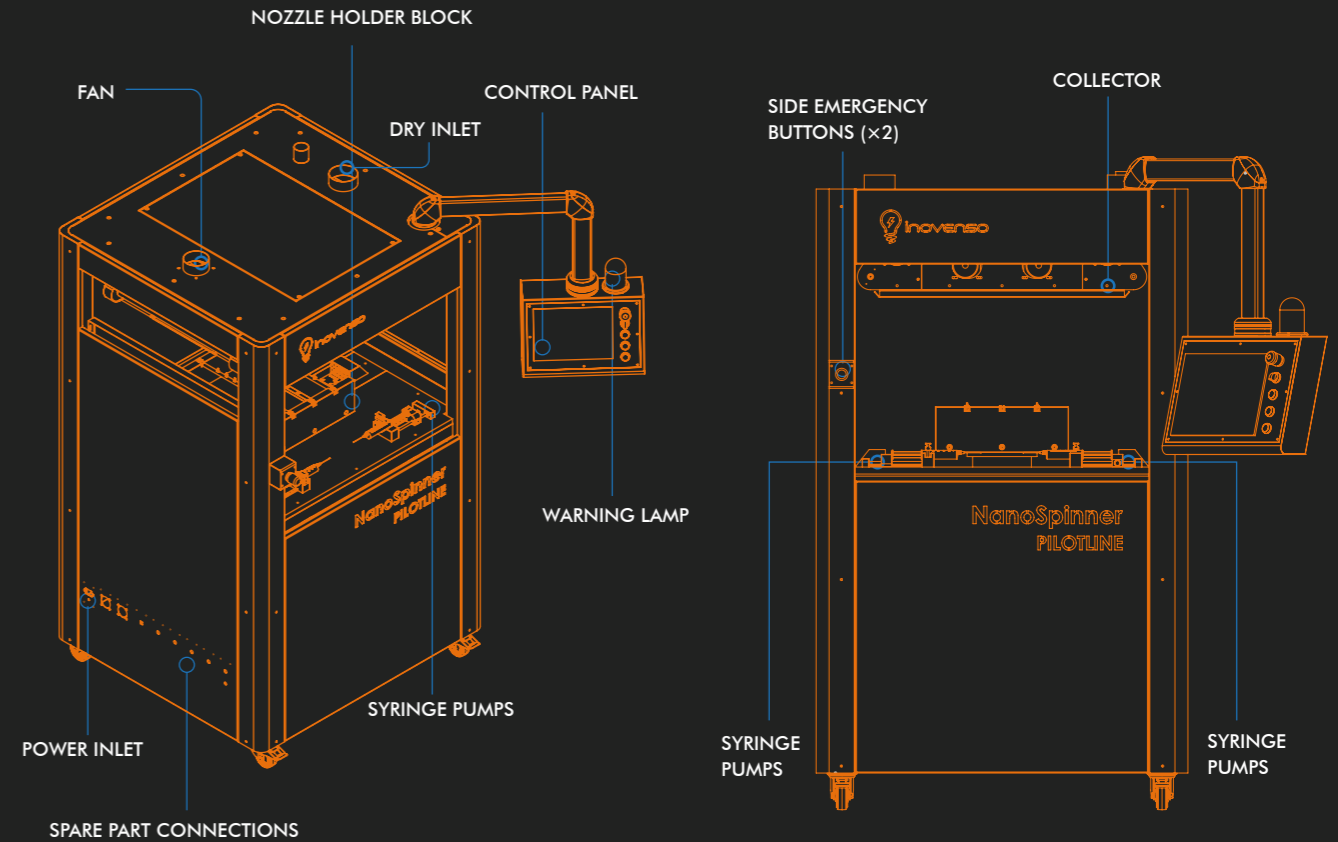

## 3D TECHNICAL DRAWING

# HYBRID ELECTROSPINNING TECHNOLOGY



# APPLICATION AREAS:

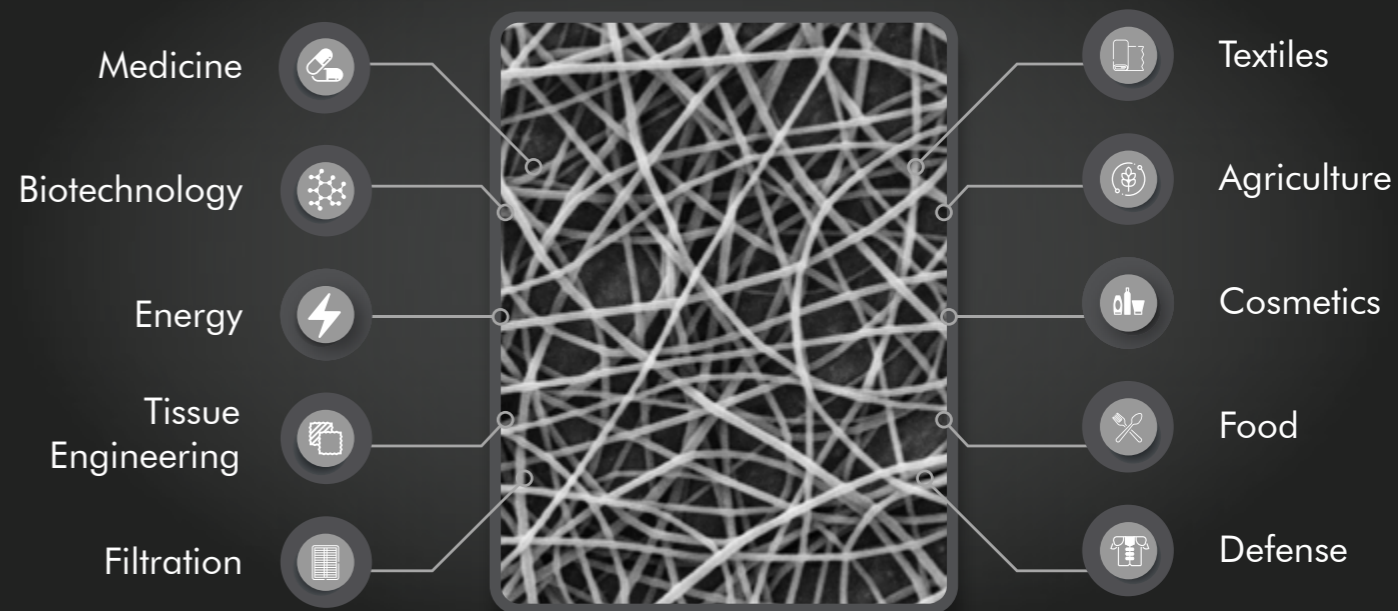







**GCW**<sup>®</sup>  
GlobalCare Wellness

 [www.electrospinning.cl](http://www.electrospinning.cl)

electrospinning.cl es parte de globalcarewellness SPA.

 [gcw@globalcarewellness.com](mailto:gcw@globalcarewellness.com)

 Santa Magdalena 75, Oficina 810, Providencia, Santiago

 +56 9 7977 1100